

A G E N D A
OCONEE COUNTY COUNCIL MEETING

TUESDAY, SEPTEMBER 17, 1996

3:00 PM

1. Call to Order
2. Invocation
3. Approval of Minutes
4. Consideration of Request of Long Creek Fire Department for a 1984 Ford L9000 No Longer Used By the County - Mr. Dewitt Mize, Rural Fire Marshal
5. Consideration of Purchasing Two Pumper Trucks in the 1996-97 Budget Based on the 1995-96 Bids as per Section B. Formal Bid Process, Subsection 2. When It Is To The Advantage of Oconee County to Acquire Goods and/or Services on the Basis of a Previously Awarded Bid or Contract - Mr. Dewitt Mize, Rural Fire Marshal
6. Consideration and Discussion of a request to apply for a State grant in the amount of \$20,000.00 to assist with the purchase of a Bookmobile for the Library System, \$20,000.00 being made through private funds and \$30,000.00 to be taken from Contingency as the cost of the Bookmobile will be approximately \$70,000.00 - Mrs. Martha Baily, Library Director
7. Consideration of awarding Bid#96-08 - Sign Materials for E-911 - Buddy Hawk, ROW/E-911 Technician, & Marianne Dillard, Purchasing Agent
8. Consideration of awarding Bid#96-09 - 2,000 gallon water tank installed on our chassis - Tommy Crumpton, Rock Crusher Director, & Marianne Dillard, Purchasing Agent
9. Consideration of awarding Bid#96-10 - (3) Scrap Metal Piles for sale - Marianne Dillard, Purchasing Agent
10. Discussion of the Hospital's Withdrawal of their proposed Land Swap agreement and possible action in regards to same - Harry Hamilton, County Council Member, District Three
11. Consideration of a Proclamation for Industry Appreciation Week
12. Old Business
13. New Business
14. Adjourn

MEMBERS, OCONEE COUNTY COUNCIL

Ms. M. Fran Burrell, District I Mr. Harrison E. Orr, District II
Mr. Harry R. Hamilton, District III Mr. Roy B. Strickland, District IV
Mr. Alton K. Williams, District V

MINUTES, OCONEE COUNTY COUNCIL MEETING

The regularly scheduled meeting of the Oconee County Council was held Tuesday, September 17, 1996 at 3:00 pm in Council Chambers with all Council Members and the County Attorney present.

Members of the press notified (by mail):
Journal/Tribune, Keowee Courier, Westminster News, Anderson Independent, Greenville News, WGOG Radio, WBFM Radio, WCCP Radio, WYFF TV & WLOS TV.

Press

Members of the press present: Dick Mangrum - WGOG Radio, Allison Glass - Anderson Independent & Ashton Hester - Keowee Courier.

The meeting was called to order by Supervisor-Chairman Crain who welcomed the guests and media.

Call to Order

The invocation was given by Mr. Williams.

Invocation

Ms. Burrell made a motion, seconded by Mr. Orr, approved 5 - 0 that the minutes of the September 3, 1996 meeting be adopted as printed.

Minutes

Upon request of Mr. Dewitt Mize, Rural Fire Marshal, Mr. David Matheson, Chief, Long Creek Fire Department, and Mr. Bobby Williams, Vice Chairman, Rural Fire Commission, Mr. Orr made a motion, seconded by Mr. Williams, approved 5 - 0 that a 1984 Ford L9000 truck, serial number 1FDYU90J2EVA34225, which is no longer used by the county be given to the Long Creek Fire Department.

Rural Fire

Mr. Strickland made a motion, seconded by Mr. Orr, approved 5 - 0 that the county provide maintenance on this vehicle.

Upon request of Mr. Mize & Mr. Williams and upon concurrence by Ms. Marianne Dillard, Purchasing Agent, Mr. Strickland made a motion, seconded by Mr. Hamilton, approved 4 - 1 (Mr. Orr voting against) that the bid procedure be waived and two (2) pumper trucks be purchased from Advanced Fire Apparatus, Inc. at \$352,514 which is the same cost as last year as per Section B. Formal Bid Process, Subsection 2. When it is to the advantage of Oconee County to acquire goods and/or services on the basis of a previously awarded bids or contracts.

Upon request of Mrs. Martha Baily, Library Director, Mrs. Maria Macaulay & Ms. Libby Lincoln, Library Board Members, Mr. Orr made a motion, seconded by Ms. Burrell, approved 5 - 0 that \$30,000 be taken from contingency and placed in line item 10 010 00150 00870 to purchase a new bookmobile if the Library can secure a state grant in the amount of \$20,000 and match it with private funds.

**Library
(Cont'cy)**

Upon recommendation of Mr. Buddy Hawk, Right-of-Way Technician, & Ms. Marianne Dillard, Purchasing Agent, it was the unanimous consent of Council that the bid for 911 materials be awarded to low bidder per item as delineated on the attached bid sheet:

911 Sign

Amsign Corporation	\$6,267.25
US Highway Products, Inc.	\$5,135.00
Newman Signs	\$1,695.00

Mr. Strickland made a motion, seconded by Mr. Williams, approved 5 - 0 that the county secure an option for a tract of land in the Long Creek area to be used as a manned convenience center and that sufficient funds to have the tract surveyed be appropriated.

**Convenience
Center**

Upon recommendation of Mr. Tommy Crumpton, Rock Crusher Director, and Ms. Dillard, Mr. Strickland made a motion, seconded by Mr. Williams, approved 5 - 0 that the technicality of the successful bidder being within one hundred, fifty (150) miles of Oconee County be waived as it would be in the best interest of the county and the bid for a two thousand (2,000) gallon water tank be awarded to Amthor International, Inc. who was low bid at \$19,975. (See attached bid sheet)

**Rock
Crusher**

Upon recommendation of Ms. Dillard, Mr. Hamilton made a motion, seconded by Mr. Strickland, approved 5 - 0 that the bid for the sale of scrap metal be awarded to Glenn's Scrap Metal who was high bid at \$907. (See attached bid sheet)

**Scrap
Metal**

After considerable discussion, Ms. Burrell made a motion, which she withdrew after point of order was called as she voted against placing a referendum regarding the matter on the November ballot (this motion was adopted by Council) that the county accept the hospital's letter to the county as a withdrawal of the proposed land exchange and to rescind the motion to place the matter on the November ballot in the form of an advisory referendum.

Hospital

After more discussion Mr. Hamilton made a motion, seconded by Mr. Orr, approved 3 - 2 (Mr. Strickland and Mr. Williams voting against) that the motion to have a referendum regarding the proposed land exchange be rescinded and the county accept the withdrawal of the hospital to exchange the property adjacent to the landfill for the property on which the hospital is situated. (See attached letter)

**Hospital
(Con't)**

Mr. Orr made a motion, seconded by Mr. Strickland, approved 5 - 0 that Proclamation 96-1, "A PROCLAMATION DECLARING SEPTEMBER 16-20 INDUSTRY APPRECIATION MONTH" be adopted on first and final reading.

Pro. 96-1

Upon request of Mr. Marion Lyles, Airport Manager, & Mr. Randy Abbott, Vice Chairman, Aeronautics Commission, Mr. Orr made a motion, seconded by Mr. Hamilton, approved 5 - 0 that an architect for the proposed terminal building at the airport be selected through Talbert & Bright as per the rules and regulations of the SC Department of Commerce, Division of Aeronautics, the Federal Aviation Administration and the EDA Grant. Further, that Talbert & Bright be permitted to engage in preliminary discussions with the architect.

Aeronautic

Ms. Dillard, Purchasing Agent, informed Council there were several departments who had requested to have parking lots paved in the 1996-97 budget year, however, based on the cost of paving, it appears there is a shortfall of some \$15,000 to \$20,000 in the budget to pave these projects. Mr. Williams made a motion, seconded by Ms. Burrell, approved 5 - 0 that the Purchasing Department secure bids for paving these parking lots.

**Parking
Lots**

Upon recommendation of Ms. Dillard, Mr. Strickland made a motion, seconded by Ms. Burrell, approved 5 - 0 that the bid process be waived and Smith Data update the computer system in the Probate Judge's Office at a cost of \$11,955 as per Section B. Formal Bid Procedure, Subsection 4. When in the Purchasing Agent's judgement, and with concurrence of County Council, it is to the advantage of the County's interest to do so.

**Probate
Judge**

To Mr. Hamilton's inquiry, Mr. Crain assured Mr. Hamilton that repairs at the Seneca Clinic were at the top of Mr. Smith's agenda.

**Health
Clinic
(Seneca)**

Mr. Orr, Chairman, Roads & Transportation Committee, reported that the committee had reviewed Connie Circle and had concluded that Mr. Hawk, Right-of-Way Technician, look at the right-of-ways on the roadway, that she could put up a fence as long as it was not in the right-of-way.

**Connie
Circle**

Mr. Cain, County Attorney assured Council he would be happy to look at Santee Roadway regarding qualification for county maintenance.

**Santee
Road**

To Mr. Strickland's inquiry, Mr. Crain informed Council the only way the fund balance could be used is through a supplemental appropriation ordinance.

**Fund
Balance**

Mr. Cain, County Attorney, informed Council he had initiated condemnation proceedings on the Elrod property and he would keep Council informed.

**Elrod
Property**

Mr. Cain also informed Council that he had received a letter from Senator Thomas Alexander in which he stated that once the research had been completed he would be happy to prepare legislation regarding public nudity.

**Public
Nudity**

Mr. Cain further informed Council the Emergency Preparedness joint exercise had been held that day with the state, federal and Duke Power representatives and it seemed to go well.

Emp. Prep.

Mr. Cain also informed Council that after the Sewer Commission and the City of Seneca gather some additional information we will be in a better position to seek grant funds to address the Newry Sewer problem.

**Newry
Sewer**

Mr. Bob Little's request for funds to purchase materials for 911 classes to be conducted in the third grades was accepted as information.

**911
Materials**

Ms. Burrell made a motion, seconded by Mr. Hamilton, approved 5 - 0 that the county accept a SC Department of Commerce Coordinating Council for Economic Development grant for road work for Compact Air Products contingent upon approval of the County Attorney.

**Compact
Air Grant**

Council scheduled the public hearing on the OCONEE COUNTY, SOUTH CAROLINA 1996 LAND USE PLAN October 10, 1996 at 7:00 pm in the courtroom.

Land Use

Mr. Crain informed Council there would be a Facilities Issues Negotiation (FIN) process meeting September 30, 1996 at 7:00 pm at the Southern Wesleyan University Auditorium, Central, SC, there is a tentative meeting scheduled October 14, 1996 and there will be a third meeting for which he had no tentative date or time.

**Regional
Landfill**

Adjourn: 5:00 pm

Adjourn

Minutes, Oconee County Council Meeting
September 17, 1996
Page 5

Submitted By:

Opal O. Green

Opal O. Green
Council Clerk

Reviewed By:

Norman D. Crain
Supervisor-Chairman
Oconee County Council

Quality **MANUFACTURING, INC.**

1420 Nimitz Avenue • Talladega, Alabama 35160

Telephone: (205) 362-9280

Fax: (205) 362-9299

TO: FIRE MARSHALL DEWITT MIZE

FROM: ROGER BAILEY

REF: FIRE TRUCK BID PO#0032066

WE WOULD LIKE TO OFFER TO THE OCONEE CO. FIRE DEPT.

TO ADD ON TO THE BID #95-24 FOR THE SAME PRICE THAT WAS

BID ON 01-03-96.

THE ONLY REQUIREMENT IS THAT YOU SIGN A WAIVER FOR THE

1901 REVISIONS THAT WERE EFFECTIVE 08-09-96.

THE DELIVERY DATES WOULD BE AS FOLLOWS: ONE TRUCK
DELIVERED IN 240 CALENDAR DAYS A.R.O. AND THE SECOND
TRUCK WILL BE DELIVERED IN 255 CALENDAR DAYS A.R.O.



ROGER BAILEY
GA. DEALER

ADVANCED FIRE APPARATUS**P.O. BOX 1608
CANTON GA 30114****OFFICE (800) 809-3755
LOCAL CALLS (706) 692-7320****PAGER (800) 809-6165
FAX (706) 692-2344****TO: DEWITT MIZE****FROM: ROGER BAILEY****REF: N.F.P.A. CHANGES****1 ALL CHASSIS OVER 36,000 LBS MUST HAVE AN AUXILLARY
BRAKE (JAKE ,TELMA,EXHAUST,TRANSMISSION)****2 ABS BRAKES ARE REQUIRED ON ALL CHASSIS THAT OFFER
THEM****3 LOW VOLTAGE WARNING LIGHT AND ALARM****4 LOAD MANAGER IS REQUIRED****5 LARGEST ALT AVAILABLE WITH MINIMUM OUT PUT AT IDLE****6 ENGING HOUR METER****7 ALL FORWARD FACING SEATS MUST HAVE 3- POINT BELTS****8 10' FOLDING LADDER****9 ADDITIONAL WARNING LIGHT ON TOP AND BOTTOM OF BODY****10 ALL EXIT STEP AREAS WILL HAVE GROUND LIGHTS****11 S.C.B.A. STORAGE TUBES WILL HAVE PADDING AND A
POSITIVE LATCH IN ADDITION TO DOORS****12 R.H. SIDE PUMP PANEL WILL BE HINGED**

OCONEE COUNTY BID TABULATION

BID FOR: Two 1996 Class A 1,250 GPM Pumper Trucks DATE: January 3, 1996

BID NO: 95-24 LOCATION: Walhalla, SC TIME: 2:00 p.m.

BIDDERS	Carolina Fire Masters , Inc.	Advanced Fire Apparatus, Inc.	Jack L. Slagle's Fire Equipment & Supply Co., Inc.	Zimmerman- Evans	Piedmont Emergency Vehicles
Base Bid- Truck #1 - Walhalla	\$199,997.00	\$174,927.00	\$186,040.00	no bid	no bid
Base Bid- Truck #2 - Westminster	199,977.00	174,927.00	186,040.00	11,113.00	
Option: 18" Extend-A-Guns	2,100.00	2,060.00	1,340.00		
SC Sales Tax	600.00	600.00	600.00		
Total	\$402,694.00	\$352,514.00	\$374,020.00		
Bid Bond	✓	✓	✓		
Insurance Certificate	✓	✓			
Manufacturer	E-One	Quality Manufacturing, Inc.	KME Fire Apparatus		
Delivery- Truck #1 - Walhalla	150-180 days ARC	280 calendar days	120-150 days ARC		
Delivery- Truck #2 - Westminster	same	300 calendar days	same		

ATTENDING OPENING: Marianne Dillard, Jenny Peay, Dewitt Mize, Tommy White-Carolina Fire Masters, Jim Rhinehart-Piedmont Emergency Vehicles. Jeff Heaton-Fire Dept #5, Roger Bailey-Advanced Fire App., Charles Lancaster-Slagle's,

08/28/96 16:07

884 638 4142

OCONEE CO PURCH

001

MEMBERS OF THE OCONEE COUNTY RURAL FIRE COMMISSION

MR. CHARLES CHALMERS, DIST. I MR. JAMES MCMAHAN, DIST II
 MR. FRANK BROACH, DIST III
 MR. CHARLES R. WILLIAMS, JR. DISTRICT IV
MR. HARRY TOLLISON, DISTRICT V MR. DOUG WILBANKS

MINUTES, OCONEE COUNTY RURAL FIRE COMMISSION

A SPECIAL MEETING OF THE OCONEE COUNTY RURAL FIRE COMMISSION WAS HELD WEDNESDAY, AUGUST 28, 1996 AT 10:00 AM IN THE MEETING ROOM OF THE LAW ENFORCEMENT CENTER IN WALHALLA, SC.

MEMBERS, OF COMMISSION PRESENT WERE;

MR. CHARLES R. WILLIAMS, JR., MR. CHARLES CHALMERS, MR. JAMES MCMAHAN, AND MR. DOUG WILBANKS.

MEMBERS OF PRESS NOTIFIED(by mail):

SENECA JOURNAL, KEOWEE PUBLICATIONS, WESTMINSTER NEWS, WGOG RADIO AND WSNW RADIO.

CALL TO ORDER

MR. CHARLES WILLIAMS CALLED THE MEETING TO ORDER.

NEW PUMPER FIRE TRUCKS

COMMISSION DISCUSSED THE PURCHASE OF TWO NEW PUMPER FIRE TRUCKS FOR BUDGET YEAR 96-97. COMMISSION DISCUSSED ADDING ON OR "TACKING ON" THE PUMPERS TO PREVIOUS ORDER WITH QUALITY MANUFACTURING. MR. JAMES MCMAHAN MADE THE MOTION TO ADD ON TO CURRENT ORDER. MR. CHARLES CHALMERS SECONDED THE MOTION. VOTE WAS UNANIMOUS.

ADJOURN

MR. CHARLES WILLIAMS MADE A MOTION TO ADJOURN.

BIDDER		Amsign Corp.			U S Highway Products, Inc.		Newman Signs		Signs & Blanks, Inc.	
QTY	DESCRIPTION	PACKAGING	UNIT PRICE	TOTAL PRICE	UNIT PRICE	TOTAL PRICE	UNIT PRICE	TOTAL PRICE	UNIT PRICE	TOTAL PRICE
1000	Series "B"-A,E,I,L,O,R,S,T	package	2.32	\$ 2,320.00	5.75	\$ 5,750.00	3.90	\$ 3,900.00	3.29	\$ 3,290.00
1300	Series "B"-B,C,D,F,G,H,K,M,N,Q,U,V,Y	package	2.32	3,016.00	5.75	7,475.00	3.90	5,070.00	3.29	4,277.00
375	Series "C"-D,R,T	package	1.49	558.75	3.00	1,125.00	2.89	1,083.75	1.68	630.00
250	Series "C"-1,2,3,4,5,6,7,8,9,0	package	1.49	372.50	3.00	750.00	2.89	722.50	1.68	420.00
	subtotal			\$ 6,267.25		\$15,100.00		\$10,776.25		\$ 8,617.00
500	VS-2 cross milled to .156	each	3.87	1,935.00	3.75	1,875.00	1.99	995.00	2.45	1,225.00
200	VS-4 UC cap to 90 bladeholder	each	3.87	774.00	4.00	800.00	3.50	700.00	4.10	820.00
	subtotal			\$ 2,709.00		\$ 2,675.00		\$ 1,695.00		\$ 2,045.00
500	6" x 36" x .135 sign blanks	each	4.54	2,270.00	4.10	2,050.00			6.56	3,280.00
500	6" x 30" x .135 sign blanks	each	3.78	1,890.00	3.45	1,725.00			5.46	2,730.00
500	6" x 24" x .135 sign blanks	each	3.03	1,515.00	2.72	1,360.00			4.38	2,190.00
	subtotal			\$ 5,675.00		\$ 5,135.00		\$ -		\$ 8,200.00
	sales tax			\$ 313.36		\$ 256.75		\$ 84.75		
	Total			\$ 6,580.61		\$ 5,391.75		\$ 1,779.75		
	DELIVERY		30 - 45 days		2 weeks		21 - 30 days		30 - 45 days	
Attended Opening: Jenny Peay, Ann Albertson, Buddy Hawk - Oconee County										

BIDDER		Vulcan Signs			3M		ADC/ Athletic Die Co.		Custom Products Corp.	
QTY	DESCRIPTION	PACKAGING	UNIT PRICE	TOTAL PRICE	UNIT PRICE	TOTAL PRICE	UNIT PRICE	TOTAL PRICE	UNIT PRICE	TOTAL PRICE
1000	Series "B"-A,E,I,L,O,R,S,T	package	2.98	\$ 2,980.00	6.16	\$ 6,160.00	3.52	\$ 3,520.00	2.75	\$ 2,750.00
1300	Series "B"-B,C,D,F,G,H,K,M,N,Q,U,V,Y	package	2.98	3,874.00	6.16	8,008.00	3.52	4,576.00	2.75	3,575.00
375	Series "C"-D,R,T	package	1.77	663.75	2.68	1,005.00	1.71	641.25	1.39	521.25
250	Series "C"-1,2,3,4,5,6,7,8,9,0	package	1.77	442.50	2.68	670.00	1.71	427.50	1.39	347.50
	subtotal			\$ 7,960.25		\$15,843.00		\$ 9,164.75		\$ 7,193.75
500	VS-2 cross milled to .156	each	2.28	1,140.00						
200	VS-4 UC cap to 90 bladeholder	each	4.29	858.00						
	subtotal			\$ 1,998.00		\$ -		\$ -		\$ -
500	6" x 36" x .135 sign blanks	each							6.50	3,250.00
500	6" x 30" x .135 sign blanks	each							5.50	2,750.00
500	6" x 24" x .135 sign blanks	each							4.50	2,250.00
	subtotal			\$ -		\$ -		\$ -		\$ 8,250.00
DELIVERY			30 days		20 - 30 days		2 weeks		14 - 28 days	

BIDDER			Hall Signs, Inc.		CDM, Inc.					
QTY	DESCRIPTION	PACKAGING	UNIT PRICE	TOTAL PRICE	UNIT PRICE	TOTAL PRICE	UNIT PRICE	TOTAL PRICE	UNIT PRICE	TOTAL PRICE
1000	Series "B"-A,E,I,L,O,R,S,T	package	3.97	\$ 3,970.00	received bid on 9-11-96					
1300	Series "B"-B,C,D,F,G,H,K,M,N,Q,U,V,Y	package	3.97	5,161.00						
375	Series "C"-D,R,T	package	2.64	990.00						
250	Series "C"-1,2,3,4,5,6,7,8,9,0	package	2.64	660.00						
	subtotal			\$ 10,781.00						
500	VS-2 cross milled to .156	each	2.42	1,210.00						
200	VS-4 UC cap to 90 bladeholder	each	3.35	670.00						
	subtotal			\$ 1,880.00						
500	6" x 36" x .135 sign blanks	each	9.03	4,515.00						
500	6" x 30" x .135 sign blanks	each	7.53	3,765.00						
500	6" x 24" x .135 sign blanks	each	6.25	3,125.00						
	subtotal			\$ 11,405.00						
	DELIVERY		30 - 45 days							

BID NO. 96- 08

(Use this number on envelopes and all related correspondence.)

BID FORM
OCONEE COUNTY PURCHASING DEPARTMENT
201 W. MAIN STREET, WALHALLA, SC 29691

The AMSIGN CORPORATION
submits herewith our Bid in response to bid request number shown above, and in compliance with the description(s) and/or specification(s), attached hereto for sign materials for E-911 Office

Quantity	Description	Unit Price	Total Price
1,000 pks.	Series "B" - 4" of A,E,I,L,O,R,S,T (125 packs of each letter)	2.32	2,320.00
1,300 pks.	Series "B" - 4" of B,C,D,F,G,H,K,M,N,Q,U,V,Y (100 packs of each letter)	2.32	3,016.00
375 pks.	Series "C" - 2" of D,R,T (125 packs of each letter)	1.49	558.75
250 pks.	Series "C" - 2" of 1, 2, 3, 4, 5, 6, 7, 8, 9, 0 (25 packs of each number)	1.49	372.50
500 ea.	VS-2 cross milled to .156	3.87	1,935.00
200 ea.	VS-4 UC cap to 90 bladeholder	3.87	774.00
500 ea.	6" x 36" x .135 sign blanks	4.54	2,270.00
500 ea.	6" x 30" x .135 sign blanks	3.78	1,890.00
500 ea.	6" x 24" x .135 sign blanks	3.03	1,515.00

Bid shall include delivery to location stated on Bid Notice.

Show any exception, deviation, extra computation, or information on Bid Supplemental Form attached hereto.

Delivery Date: 30-45 DAYS

Bidding Organization: AMSIGN CORPORATION

Address: 749 New Ludlow Rd, South Haddam, MA 01025

Signature of Bidders Representative: Ronald E Whiteaker

Title: President Date: 9/4/96

Telephone: (413) 535-2100

BID NO. 96- 08

(Use this number on envelopes and all related correspondence.)

BID FORM
OCONEE COUNTY PURCHASING DEPARTMENT
201 W. MAIN STREET, WALHALLA, SC 29691

The U.S. HIGHWAY PRODUCTS, INC.
 submits herewith our Bid in response to bid request number shown above, and in compliance with the description(s) and/or specification(s) attached hereto for sign materials for E-911 Office

Quantity	Description	Unit Price	Total Price
1,000 pks.	Series "B" - 4" of A,E,I,L,O,R,S,T (125 packs of each letter)	\$5.75	\$5,750 ⁰⁰
1,300 pks.	Series "B" - 4" of B,C,D,F,G,H,K,M,N,Q,U,V,Y (100 packs of each letter)	\$5.75	\$7,475 ⁰⁰
375 pks.	Series "C" - 2" of D,R,T (125 packs of each letter)	\$3.00	\$1,125 ⁰⁰
250 pks.	Series "C" - 2" of 1, 2, 3, 4, 5, 6, 7, 8, 9, 0 (25 packs of each number)	\$3.00	\$750 ⁰⁰
500 ea.	VS-2 cross milled to .156 E103 ^{CROSS PILE} _{W/ 3 3/8" SLOT}	\$3.75	\$1,875 ⁰⁰
200 ea.	VS-4 UC cap to 90 bladeholder E101-90 ^{90° CAP} _{W/ 3-3/8" SLOT}	\$4.00	\$800 ⁰⁰
500 ea.	6" x 36" x .135 sign blanks (FIBERBRITE™)	\$4.10	\$2,050 ⁰⁰
500 ea.	6" x 30" x .135 sign blanks (FIBERBRITE™)	\$3.45	\$1,725 ⁰⁰
500 ea.	6" x 24" x .135 sign blanks (FIBERBRITE™)	\$2.72	\$1,360 ⁰⁰

Bid shall include delivery to location stated on Bid Notice.

Show any exception, deviation, extra computation, or information on Bid Supplemental Form attached hereto.

Delivery Date: 2 WEEK ARO

Bidding Organization: U.S. HIGHWAY PRODUCTS, INC.

Address: 114 PORTER ST. Rear / WATERBURY, CT 06708

Signature of Bidders Representative: Mark R. [Signature]

Title: Account Representative Date: 9-3-96

Telephone: 1-800-883-8363

BID SUPPLEMENTAL FORM

OCONEE COUNTY PURCHASING DEPARTMENT

201 WEST MAIN STREET

WALHALLA, SOUTH CAROLINA 29691

DATE: 9-3-96 BID NO. 96-08

The U.S. Highway Products, Inc. takes the following exceptions:
(Bidder)

V5-2 Cross milled to .156 → Bidding E103 90° cross piece w/3-3/8" slot
milled to .160

US-4 UC cap to 90° bladeholder → E101-90 90° U-channel cap w/3-3/8" slot

SIGNATURE: Mark R. Wilson

BID NO. 96- 08

(Use this number on envelopes and all related correspondence.)

BID FORM
OCONEE COUNTY PURCHASING DEPARTMENT
201 W. MAIN STREET, WALHALLA, SC 29691

The Newman Sign, Inc.

submits herewith our Bid in response to bid request number shown above, and in compliance with the description(s) and/or specification(s) attached hereto for sign materials for E-911 Office

Quantity	Description	Unit Price	Total Price
1,000 pks.	Series "B" - 4" of A,E,I,L,O,R,S,T (125 packs of each letter)	3.90	3900.00
1,300 pks.	Series "B" - 4" of B,C,D,F,G,H,K,M,N,Q,U,V,Y (100 packs of each letter)	3.90	5070.00
375 pks.	Series "C" - 2" of D,R,T (125 packs of each letter)	2.89	1083.75
250 pks.	Series "C" - 2" of 1, 2, 3, 4, 5, 6, 7, 8, 9, 0 (25 packs of each number)	2.89	722.50
500 ea.	VS-2 cross milled to .156	1.99	995.00
200 ea.	VS-4 UC cap to 90 bladeholder	3.50	700.00
500 ea.	6" x 36" x .135 sign blanks	No Bid	—
500 ea.	6" x 30" x .135 sign blanks	No Bid	—
500 ea.	6" x 24" x .135 sign blanks	No Bid	—

Bid shall include delivery to location stated on Bid Notice.

Show any exception, deviation, extra computation, or information on Bid Supplemental Form attached hereto.

Delivery Date: 21-30 days

Bidding Organization: Newman Signs, Inc.

Address: PO Box 1728 / 1606 6th Ave SW Jamestown, ND 58402

Signature of Bidders Representative: Marchelle Ebbensgard

Title: Sales Representative Date: 8-30-96

Telephone: 1-800-437-9770 ext. 161

BID NO. 96- 08
 (Use this number on envelopes and all related correspondence.)

BID FORM
OCONEE COUNTY PURCHASING DEPARTMENT
 201 W. MAIN STREET, WALHALLA, SC 29691

The SIGNS AND BLANKS, INC.

submits herewith our Bid in response to bid request number shown above, and in compliance with the description(s) and/or specification(s) attached hereto for sign materials for E-911 Office

Quantity	Description	Unit Price	Total Price
1,000 pks.	Series "B" - 4" of A,E,I,L,O,R,S,T (125 packs of each letter)	3.29	3,290.00
1,300 pks.	Series "B" - 4" of B,C,D,F,G,H,K,M,N,Q,U,V,Y (100 packs of each letter)	3.29	4,277.00
375 pks.	Series "C" - 2" of D,R,T (125 packs of each letter)	1.68	630.00
250 pks.	Series "C" - 2" of 1, 2, 3, 4, 5, 6, 7, 8, 9, 0 (25 packs of each number)	1.68	420.00
500 ea.	VS-2 cross milled to .156 606F	2.45	1,225.00
200 ea.	VS-4 UC cap to 90 bladeholder #808F	4.10	820.00
500 ea.	6" x 36" x .135 sign blanks * NO HOLES -	6.56	3,280.00
500 ea.	6" x 30" x .135 sign blanks * STANDARD	5.46	2,730.00
500 ea.	6" x 24" x .135 sign blanks * CORNERS-1 1/2"	4.38	2,190.00
*	Quoting .080 ALUMINUM-COVERED WITH ENGINEER GRADE-REFLECTIVE	BOTH SIDES GREEN SHEETING	

Bid shall include delivery to location stated on Bid Notice.

\$10,662.00

Show any exception, deviation, extra computation, or information on Bid Supplemental Form attached hereto.

Delivery Date: 30/45 DAYS ARO

Bidding Organization: SIGNS AND BLANKS, INC.

Address: P.O. Box 2234
Akron, Oh 44309-2234

Signature of Bidders Representative: Edrup C. Jambler

Title: Gov. + Bid Mgr. Date: 9-5-96

Telephone: 800 837-2245

2.35
1.06
57

BID SUPPLEMENTAL FORM
OCONEE COUNTY PURCHASING DEPARTMENT
201 WEST MAIN STREET
WALHALLA, SOUTH CAROLINA 29691

DATE: 9/5/96 BID NO. 96-08

The Signs and Blanks, Inc. takes the following exceptions:
(Bidder)

For the 6" Blades; quoting .080 aluminum, covered both sides with engineer grade reflective green, no holes, standard radius corners 1-1/2".

Brackets: Cross #606F - UC Cap #808F Literature attached.

Terms: Net 30 Days

Prices are firm for 60 Days.

SIGNATURE: _____

Redrup C. Simblin

BID NO. 96- 08

(Use this number on envelopes and all related correspondence.)

BID FORM
OCONEE COUNTY PURCHASING DEPARTMENT
201 W. MAIN STREET, WALHALLA, SC 29691

The VULCAN SIGNS

submits herewith our Bid in response to bid request number shown above, and in compliance with the description(s) and/or specification(s) attached hereto for sign materials for E-911 Office

Quantity	Description	Unit Price	Total Price
1,000 pks.	Series "B" - 4" of A,E,I,L,O,R,S,T (125 packs of each letter)	\$2.98	\$2,980.00
1,300 pks.	Series "B" - 4" of B,C,D,F,G,H,K,M,N,Q,U,V,Y (100 packs of each letter)	2.98	3,874.00
375 pks.	Series "C" - 2" of D,R,T (125 packs of each letter)	1.77	663.75
250 pks.	Series "C" - 2" of 1, 2, 3, 4, 5, 6, 7, 8, 9, 0 (25 packs of each number)	1.77	442.50
500 ea.	VS-2 cross milled to .156	2.28	1,140.00
200 ea.	VS-4 UC cap to 90 bladeholder	4.29	858.00
500 ea.	6" x 36" x .135 sign blanks	NO BID	
500 ea.	6" x 30" x .135 sign blanks	NO BID	
500 ea.	6" x 24" x .135 sign blanks	NO BID	

Bid shall include delivery to location stated on Bid Notice.

Show any exception, deviation, extra computation, or information on Bid Supplemental Form attached hereto.

Delivery Date: 30 DAYS ARO

Bidding Organization: VULCAN SIGNS

Address: P.O. BOX 1850, FOLEY, ALABAMA 36536-1850

Signature of Bidders Representative: *Eric L. Crosby* ERICK L. CROSBY

Title: SALES/PRODUCT MANAGER Date: 09/06/96

Telephone: 800-633-6845

BID NO. 96- 08

(Use this number on envelopes and all related correspondence.)

BID FORM
OCONEE COUNTY PURCHASING DEPARTMENT
201 W. MAIN STREET, WALHALLA, SC 29691

The 3M

submits herewith our Bid in response to bid request number shown above, and in compliance with the description(s) and/or specification(s) attached hereto for sign materials for E-911 Office

Quantity	Description	Unit Price	Total Price
1,000 pks.	3M Br "SCOTCHLITE" #3290 White Series "B" - 4" of A,E,I,L,O,R,S,T (125 packs of each letter)	6.16	6160.00
1,300 pks.	Series "B" - 4" of B,C,D,F,G,H,K,M,N,Q,U,V,Y (100 packs of each letter) 3M Br "SCOTCHLITE" 3290 White	6.16	8008.00
375 pks.	Series "C" - 2" of D,R,T (125 packs of each letter) 3M Brand "SCOTCHLITE" 3290 White	2.68	1005.00
250 pks.	Series "C" - 2" of 1, 2, 3, 4, 5, 6, 7, 8, 9, 0 (25 packs of each number) 3M Br "SCOTCHLITE" 3290	2.68	670.00
500 ea.	VS-2 cross milled to .156	NO BID	
200 ea.	VS-4 UC cap to 90 bladeholder	""	
500 ea.	6" x 36" x .135 sign blanks	""	
500 ea.	6" x 30" x .135 sign blanks	""	
500 ea.	6" x 24" x .135 sign blanks	""	
		""	

Bid shall include delivery to location stated on Bid Notice.

total: 15,843.00

+ APPL SALES TAX

Show any exception, deviation, extra computation, or information on Bid Supplemental Form attached hereto.

Delivery Date: 20-30 days ARO

Bidding Organization: 3M

Address: 3M Center Bldg. 225-5S 08, Box 33225 St Paul, MN 55133-3225

Signature of Bidders Representative: Dennis J. Johnson

Title: Dennis J. Johnson/Supvr of Gov't Bids & Contracts Date: 8/29/96

Telephone: 612-733-0582

BID NO. 96-08

(Use this number on envelopes and all related correspondence.)

BID FORM
OCONEE COUNTY PURCHASING DEPARTMENT
201 W. MAIN STREET, WALHALLA, SC 29691

The ADC / Athletic Die Company
submits herewith our Bid in response to bid request number shown above, and in compliance with the description(s) and/or specification(s) attached hereto for sign materials for E-911 Office

Quantity	Description	Unit Price	Total Price
1,000 pks.	Series "B" - 4" of A,E,I,L,O,R,S,T (125 packs of each letter)	3.52 ^{pk.}	3520.00
1,300 pks.	Series "B" - 4" of B,C,D,F,G,H,K,M,N,Q,U,V,Y (100 packs of each letter)	3.52 ^{pk.}	4576.00
375 pks.	Series "C" - 2" of D,R,T (125 packs of each letter)	1.71 ^{pk.}	641.25
250 pks.	Series "C" - 2" of 1, 2, 3, 4, 5, 6, 7, 8, 9, 0 (25 packs of each number)	1.71 ^{pk.}	427.50
500 ea.	VS-2 cross milled to .156	No Bid	
200 ea.	VS-4 UC cap to 90 bladeholder	No Bid	
500 ea.	6" x 36" x .135 sign blanks	No Bid	
500 ea.	6" x 30" x .135 sign blanks	No Bid	
500 ea.	6" x 24" x .135 sign blanks	No Bid	

Bid shall include delivery to location stated on Bid Notice.

Show any exception, deviation, extra computation, or information on Bid Supplemental Form attached hereto.

Delivery Date: 2 weeks

Bidding Organization: ADC / Athletic Die Company

Address: 2160-B Sadler Rd Amelia Island, FL 32034

Signature of Bidders Representative: Carol Miller

Title: Dist Sales Manager Date: 8-26-96

Telephone: 1-800-874-8674

BID NO. 96- 08

(Use this number on envelopes and all related correspondence.)

BID FORM
OCONEE COUNTY PURCHASING DEPARTMENT
201 W. MAIN STREET, WALHALLA, SC 29691

The CUSTOM PRODUCTS CORPORATION

submits herewith our Bid in response to bid request number shown above, and in compliance with the description(s) and/or specification(s) attached hereto for sign materials for E-911 Office

Quantity	Description	Unit Price	Total Price
1,000 pks.	Series "B" - 4" of A,E,I,L,O,R,S,T (125 packs of each letter)	2.75	2750.00
1,300 pks.	Series "B" - 4" of B,C,D,F,G,H,K,M,N,Q,U,V,Y (100 packs of each letter)	2.75	3575.00
375 pks.	Series "C" - 2" of D,R,T (125 packs of each letter)	1.39	521.25
250 pks.	Series "C" - 2" of 1, 2, 3, 4, 5, 6, 7, 8, 9, 0 (25 packs of each number)	1.39	347.50
500 ea.	VS-2 cross milled to .156	NO BID	
200 ea.	VS-4 UC cap to 90 bladeholder	NO BID	
500 ea.	6" x 36" x .135 sign blanks	6.50	3250.00
500 ea.	6" x 30" x .135 sign blanks	5.50	2750.00
500 ea.	6" x 24" x .135 sign blanks	4.50	2250.00

Bid shall include delivery to location stated on Bid Notice.

Show any exception, deviation, extra computation, or information on Bid Supplemental Form attached hereto.

Delivery Date: 14-28 DAYS

Bidding Organization: CUSTOM PRODUCTS CORPORATION

Address: P.O. BOX 54091 JACKSON, MS 39288

Signature of Bidders Representative: Hal Perkins / HAL PERKINS

Title: MARKETING Date: 9/3/96

Telephone: 800-367-1492

BID NO. 96-08

(Use this number on envelopes and all related correspondence.)

BID FORM
OCONEE COUNTY PURCHASING DEPARTMENT
201 W. MAIN STREET, WALHALLA, SC 29691

The _____
submits herewith our Bid in response to bid request number shown above, and in compliance with the description(s) and/or specification(s) attached hereto for sign materials for E-911 Office

Quantity	Description	Unit Price	Total Price
1,000 pks.	Series "B" - 4" of A,E,I,L,O,R,S,T (125 packs of each letter)	\$3.97	\$3970.00
1,300 pks.	Series "B" - 4" of B,C,D,F,G,H,K,M,N,Q,U,V,Y (100 packs of each letter)	\$3.97	\$5161.00
375 pks.	Series "C" - 2" of D,R,T (125 packs of each letter)	\$2.64	\$990.00
250 pks.	Series "C" - 2" of 1, 2, 3, 4, 5, 6, 7, 8, 9, 0 (25 packs of each number)	\$2.64	\$660.00
500 ea.	VS-2 cross milled to .156	\$2.42	\$1210.00
200 ea.	VS-4 UC cap to 90 bladeholder	\$3.35	\$670.00
500 ea.	6" x 36" x .135 sign blanks	\$9.03	\$4515.00
500 ea.	6" x 30" x .135 sign blanks	\$7.53	\$3765.00
500 ea.	6" x 24" x .135 sign blanks	\$6.25	\$3125.00

Bid shall include delivery to location stated on Bid Notice.

Show any exception, deviation, extra computation, or information on Bid Supplemental Form attached hereto.

Delivery Date: 30-45 DAYS ARO

Bidding Organization: HALL SIGNS, INC.

Address: P.O. BOX 515-BLOOMINGTON, IN. 47402

Signature of Bidders Representative: Becky Anderson

Title: BID COORDINATOR Date: 9-9-96

Telephone: 800-284-7446

BID SUPPLEMENTAL FORM

OCONEE COUNTY PURCHASING DEPARTMENT

201 WEST MAIN STREET

WALHALLA, SOUTH CAROLINA 29691

DATE: 9-9-96 BID NO. 96-08

The HALL SIGNS, INC. takes the following exceptions:
(Bidder)

VS-4 UC CAP TO 90 BLADEHOLDER
BIDDING: HALL SIGNS #922F

VS-2 CROSS MILLED TO .156

BIDDING: HALL SIGNS #2-ROC-PRUF

"SEE BROCHURE ENCLOSED"

SIGNATURE: Bicky Anderson



09-09-96

OCONEE COUNTY PURCHASING DEPARTMENT
201 WEST MAIN STREET
WALHALLA, SC 29691

BID RE: #96-08
OPENS: 9/10/96 AT 2:00 PM

* NET 30 DAYS/ 0% DISCOUNT

FOB: DELIVERED
SHIPMENT: 30 - 45 DAYS ARO

QUOTING: SIGN MATERIALS FOR E-911 OFFICE
EXCEPTIONS LISTED & BROCHURE ENCLOSED

MINIMUM ORDERS:

* Please note: Our freight carriers do not carry equipment to unload at your dock. Prices are for delivery to your dock only.

If you have any questions or wish to place an order please call Becky Anderson at Ext. 106, 800-284-7446.

Thank you,

Becky Anderson,
Bid Coordinator

BA:aed

cc: file

traffic • custom • materials

Hall Signs, Incorporated
4495 West Vernal Pike, P.O. Box 515, Bloomington, Indiana 47404
(812) 332-9355 voice • (800) 284-7446 toll free • (812) 332-9816 fax

BIDDER	Amthor International, Inc.	Interstate Equipment Co.	Oilmen's Truck Tanks, Inc.	
Total Bid Price (installed at Bidder's Shop)	\$ 19,975.00	\$ 34,825.00	\$ 54,573.00	
Option: Bid Price (installed at Rock Quarry)	no bid	no bid	no bid	
Delivery	45 days ARO	45 - 60 days ARO	18 - 20 weeks ARO	
Attended Bid Opening: Marianne Dillard, Jenny Peay, Tommy Crumpton - Oconee County, Rob Gregory, Mark Dantzler - Interstate Equipment				

BID NO. 96-09

(Use this number on envelopes and all related correspondence.)

**BID FORM
OCONEE COUNTY PURCHASING DEPARTMENT
201 W. MAIN STREET, WALHALLA, SC 29691**

The AMTHOR INTERNATIONAL, INC. GRETNA, VA
submits herewith our Bid in response to bid request number shown above, and in compliance with the description(s) and/or specification(s) attached hereto for 2,000 gallon water tank installed on our 1996 Ford F800 truck

TOTAL Bid Price (Installed at Bidder's Shop) \$ 19,975.00

OPTION:

Bid Price (Installed at Oconee County Rock Quarry) \$ 0.00

Bid shall include delivery to location stated on Bid Notice.

Show any exception, deviation, extra computation, or information on Bid Supplemental Form attached hereto.

Delivery Date: 45 DAYS AFTER RECEIPT OF SIGNED ORDER & CHASSIS RECEIVED

Bidding Organization: AMTHOR INTERNATIONAL, INC.

Address: 237 INDUSTRIAL DRIVE GRETNA, VA 24557

Signature of Bidders Representative: *[Handwritten Signature]*

Title: FACTORY REPRESENTATIVE Date: 9/8/96

Telephone: (804) 656-6233 FAX: (804) 656-1101

BID SUPPLEMENTAL FORM
OCONEE COUNTY PURCHASING DEPARTMENT
201 WEST MAIN STREET
WALHALLA, SOUTH CAROLINA 29691

DATE: SEPTEMBER 9, 1996 BID NO. 96-09

The AMTHOR INTERNATIONAL, INC. takes the following exceptions:
(Bidder)

"NONE"

NOTE: YOUR SPECIFICATIONS SAY YOU HAVE A 30,000LBS GVWR, PLEASE BE AWARE THAT THE GVWR OF YOUR CHASSIS SEEMS LIGHT FOR THE TANK THAT YOU ARE REQUESTING:

APPROX CHASSIS WEIGHT	10,000 LBS
2000 GALLONS OF WATER	16,666 LBS
APPROX TANK & EQUIP.	6,500 LBS
TOTAL APPROX	<u>33,166 LBS</u>

IF YOU HAVE ANY QUESTIONS PLEASE FEEL FREE TO CALL ME AT ANY TIME, AT (804) 656-6233.

BUTCH AMTHOR
EXECUTIVE VICE PRESIDENT

SIGNATURE: _____

FACTORY SALES REPRESENTATIVE H. STEPHEN COFFEE

Proposal

(804) 656-6233



P No 540

237 INDUSTRIAL DRIVE GREINA, VA 24557

PROPOSAL SUBMITTED TO: OCONEE COUNTY PURCHASING DEPARTMENT	PHONE: (864) 638-4141	DATE: 9/9/96
STREET UPS: 201 W. MAIN STREET / MAILING: 208 BOOKER DRIVE	SALESMAN: BUTCH AMTHOR / STEVE COFFEE	
CITY, STATE AND ZIP CODE: WALHALLA, SC 29691	TERMS - 20 Percent Down Payment - Balance due at time of delivery	

We hereby submit specifications and estimates for:
1 - 2000 GALLON STEEL CARDINAL CHAMPION TANK--WATER ONE COMPARTMENT.

CONSTRUCTION TO BE 1/4" VEE TYPE LONGMEMBERS, 7 GAUGE FLOOR & BULKHEADS, 10 GAUGE SIDES & BAFFLES. ALL HEADS DISHED AND FLANGED. TANK TO BE MOUNTED ON CHASSIS USING AIR DRIED OAK SILLS. TANK TIED TO CHASSIS NAILS BY 3 SETS EACH SIDE OF 5/8" TIE STRAPS. REAR FENDERS TO BE INTEGRAL WITH TANK AND WILL BE CONSTRUCTED FROM 12 GAUGE TREAD PLATE STEEL. ONE 20" TOP MANWAY. ONE LADDER TO TOP MANWAY. TANK FLOOR TO BE EXTENDED TO HOLD WATER PUMP, HYDRAULIC RESERVIOR AND PIPING. ONE REAR HYDRANT FILL WITH AIR SPACE ON TOP, WITH 4" WAFER VALVE, STRAINER, EVERTITE & CAP. TANK INTERIOR WILL BE SANBLASTED AND COATED WITH RUSTOLEUM 9000 SERIES EPOXY. ONE REAR BUMPER WILL BE INSTALLED, ALL ICC-DOT LIGHTING TO MEET MCI08 REGULATIONS. ONE TANK CAPACITY SIGET GAUGE WILL BE INSTALLED IN FRONT OF TANK. ONE 3" TTMA SUMP IN FLOOR OF TANK.

*****EQUIPMENT*****

ONE MUNICE HD 2--GEAR PTO WITH AIR SHIFT ATTACHED TO ONE CLOSE COUPLED MUNICE HYDRAULIC PUMP. PRESSURE & SUCTION TUBES RUN THROUGH TANK TO KEEP OIL COOL. ONE BERKLEY WATER PUMP ATTACHED TO ONE MUNICE HYDRAULIC MOTOR INSTALLED ON REAR PLATFORM. ONE 25 GALLON HYDRAULIC OIL RESERVIOR WITH RETURN LINE FILTER AND GAUGE INSTALLED ON REAR PLATFORM. ONE 3" TANK FILL WITH VALVE. ONE 3" SUCTION LINE FOR DRAFTING WITH VALVE, EVERTITE & CAP. TWO MIDSHIP NOZZLES--ONE LEFT & ONE RIGHT ADJUSTABLE WITH CLAYTON AIR VALVES. TWO BRASS NOZZLES IN REAR OF UNIT--ONE EACH SIDE. ONE CONSOLE IN CAB TO OPERATE ALL VALVES SEPARTELY. ONE 3" REMOTE CONTROL CANNON AHEAD OF TANK AND BEHIND CAB. CANNON TO BE CONTROLLED FROM CAB. ONE 8' SPRAY BAR IN REAR WITH BRASS NOZZLES. TWO LENGTHS 3" X 10' ON LOADING HOSE. ONE MANUAL HOSE REEL WITH 100'-1 1/2" HOSE, SHUT OFF NOZZLE.

UNIT INSTALLED, TESTED, PAINTED ONE COLOR AND DELIVERED TO OCONEE COUNTY, WALHALLA, SC
 PRICE: \$19,975.00

We propose to furnish material and labor complete in accordance with above specifications, for the sum of:
 ----- NINETEEN THOUSAND NINE HUNDRED SEVENTY-FIVE----- dollars (\$ 19,975.00)
 Payment to be made as follows:
 TOTAL DUE UPON DELIVERY OF UNIT.

All work is guaranteed to be as specified. All work to be completed in a workable manner according to standard practices. Any alteration or addition from above specifications involving extra costs will be executed only upon written orders and will become an extra charge over and above the estimate. All agreements participant upon strikes, accidents or delays beyond our control. We are to carry fire, tornado and other necessary insurance. Our workers are fully covered by Workmen's Compensation insurance.

Authorized Signature: *Butch Amthor*
 Note: This Proposal may be withdrawn by us if not accepted within 30 days.

Acceptance of Proposal - The above prices, specifications and conditions are satisfactory and are hereby accepted. You are authorized to do the work as specified. A _____ % deposit is required at time proposal is accepted. All unit C.O.D. upon delivery or pick up.
 All Checks Over \$1000.00 to be a Certified or Bank Check.

Date of Acceptance: _____ Signature: _____

BID NO. 96-09

(Use this number on envelopes and all related correspondence.)

BID FORM
OCONEE COUNTY PURCHASING DEPARTMENT
201 W. MAIN STREET, WALHALLA, SC 29691

The INTERSTATE EQUIPMENT COMPANY
submits herewith our Bid in response to bid request number shown above, and in compliance with the description(s) and/or specification(s) attached hereto for 2,000 gallon water tank installed on our 1996 Ford F800 truck

TOTAL Bid Price (Installed at Bidder's Shop) \$ 34,825.00

OPTION:

Bid Price (Installed at Oconee County Rock Quarry) \$ _____

Bid shall include delivery to location stated on Bid Notice.

Show any exception, deviation, extra computation, or information on Bid Supplemental Form attached hereto.

Delivery Date: 45 - 60 DAYS ARO

Bidding Organization: INTERSTATE EQUIPMENT COMPANY

Address: 122 GARDNERS TERRACE ROAD, WEST COLUMBIA, SC 29172

Signature of Bidders Representative:  / G. MARK DANTZLER

Title: VICE PRESIDENT Date: SEPTEMBER 10, 1996

Telephone: (803) 794-7400

BID SUPPLEMENTAL FORM

OCONEE COUNTY PURCHASING DEPARTMENT

201 WEST MAIN STREET

WALHALLA, SOUTH CAROLINA 29691

DATE: September 10, 1996 BID NO. 96-09

The INTERSTATE EQUIPMENT COMPANY takes the following exceptions:
(Bidder)

"LOAD LINE: ...4" LINE LOCATED AT REAR OF TANK WITH STRAINER."
ROSCO WILL SUPPLY A 3" QUICK COUPLER ON TANK REAR FOR FILLING
IN ADDITION TO 2 1/2" AIR GAP FILL INTO MANHOLE WHICH HAS A
FULL SECTION SCREEN. ALSO WITH SUCTION FILL OPTION A STRAINER
WILL BE PROVIDED FOR END OF HOSE.

SIGNATURE: 

RUSCO CORPORATE INTERSTATE-W COL

INVOICE NO. Proposal

RUSCO W/ FLUSHER S.N. _____

TANK SIZE 49x90x120 LONG-CAPACITY- U.S. GALLONS (RATED) 2000
U.S. GALLONS (ACTUAL) 2016

FLUSHER WT. EMPTY _____ 5200 (ESTIMATED)

LOAD AT 8.3 LB'S. PER GALLON, TOTAL WT. - 16600

FLUSHER, TOTAL WT. LOADED _____ 21800

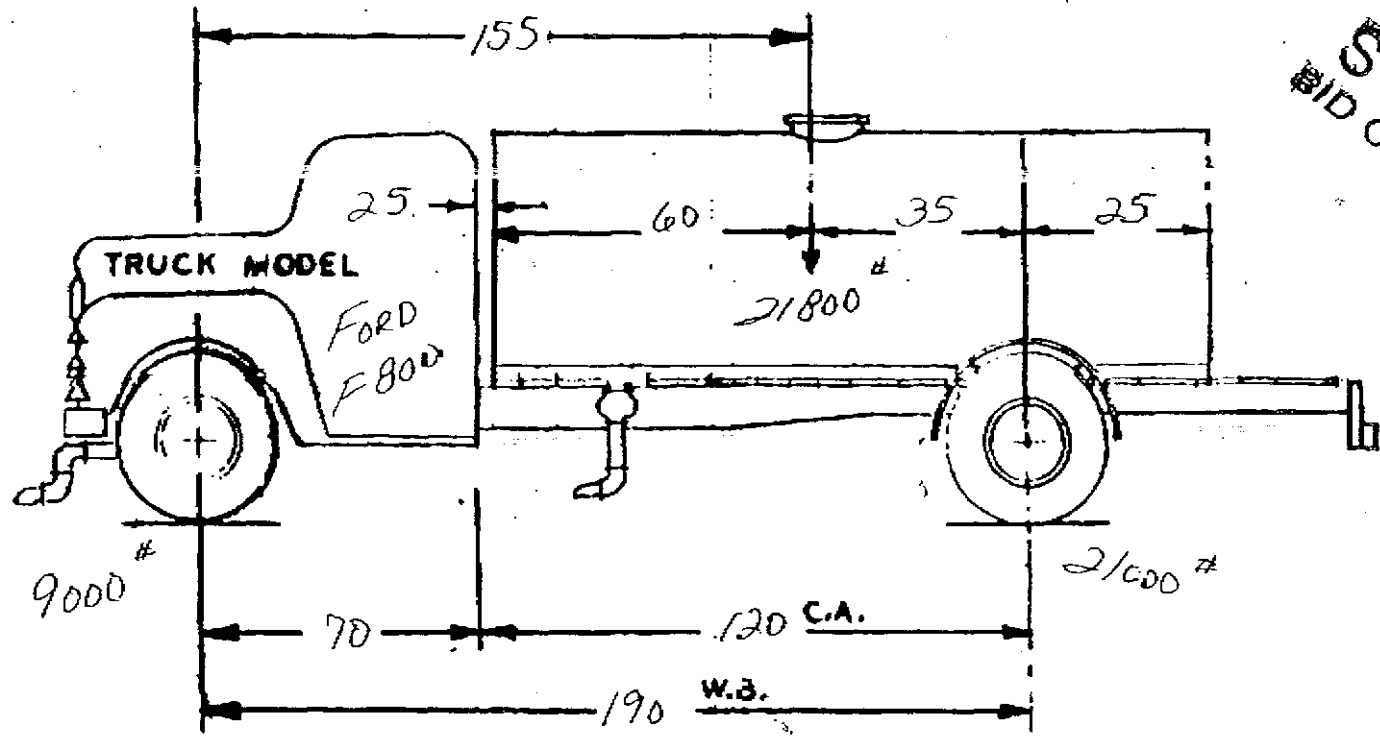

STAGE I
BID OR ORDER

<u>5200</u>	-TRUCK WEIGHT	(ACTUAL)	-	<u>3400</u>
<u>4016</u>	-FLUSHER LOADED WEIGHT	(ESTIMATED)	-	<u>17784</u>
<u>9216</u>	TOTAL AXLE LOAD			<u>21184</u>

DEALER - Interstate Equip.
 CUSTOMER PROPOSAL FOR - Oconee Co.
 DATE - 08/29/96
 V.I.N. - _____

BID NO. 96-09

(Use this number on envelopes and all related correspondence.)

BID FORM
OCONEE COUNTY PURCHASING DEPARTMENT
201 W. MAIN STREET, WALHALLA, SC 29691

The Oilmen's Truck Tanks Inc.
submits herewith our Bid in response to bid request number shown above, and in compliance with the description(s) and/or specification(s) attached hereto for 2,000 gallon water tank installed on our 1996 Ford F800 truck

TOTAL Bid Price (Installed at Bidder's Shop) \$ 54,573.00

OPTION:

Bid Price (Installed at Oconee County Rock Quarry) \$ N/A

Bid shall include delivery to location stated on Bid Notice.

Show any exception, deviation, extra computation, or information on Bid Supplemental Form attached hereto.

Delivery Date: 18 to 20 Weeks After Receipt of Order

Bidding Organization: Oilmen's Truck Tanks, Inc.

Address: 140 Cedar Spring Road, Spartanburg, SC 29302

Signature of Bidders Representative: *Garry Cochran*

Title: Operations Manager Date: September 10, 1996

Telephone: 800-859-8265 / 864-573-7400

BID SUPPLEMENTAL FORM
OCONEE COUNTY PURCHASING DEPARTMENT
201 WEST MAIN STREET
WALHALLA, SOUTH CAROLINA 29691

DATE: September 10, 1996 BID NO. 96-09

The Oilmen's Truck Tanks, Inc. takes the following exceptions:
(Bidder)

If approved, we recommend Gorman Rupp pump in lieu of Hile pump and priming system.

Water cannon manufacturer is Akron.

Flusher nozzles are manufactured by Rite.

The enclosed description of water tankers were very general. If we are successful bidder we would like a detailed order of placement of components and finished unit.

SIGNATURE: _____

Larry Cochran
Larry Cochran

BID FORM

I hereby submit a bid of \$ 907.00 for the scrap metal pile located at the Oconee County Motor Pool, the Rock Quarry and the Road Department.

If I am the successful bidder, I agree to have all items moved within two weeks after I am notified.

Name: GLENN'S SCRAP METALS

Address: 428 SAM MOORE RD.
WESTMINSTER, S.C. 29693

Phone: 864-647-1623

Date: 09-04-96

Please show the following bid/quote number on the lower left corner of the envelope - BID NO. 96-10.

BID FORM

I hereby submit a bid of \$ 700⁰⁰ for the scrap metal pile located at the Oconee County Motor Pool, the Rock Quarry and the Road Department.

If I am the successful bidder, I agree to have all items moved within two weeks after I am notified.

Name: Cobb Salvage

Address: 255 Lakeview Drive

Walhalla, S.C. 29691

Phone: 638-7417

Date: _____

Please show the following bid/quote number on the lower left corner of the envelope - BID NO. 96-10.

BID FORM

I hereby submit a bid of \$ \$626.00 for the scrap metal pile located at the Oconee County Motor Pool, the Rock Quarry and the Road Department.

If I am the successful bidder, I agree to have all items moved within two weeks after I am notified.

Name: Clev Phillips

Address: 1159 Strubling Shoals RD
Walhalla S.C 29691

Phone: 638-8334 or 972-4047

Date: September 4 - 1996

Please show the following bid/quote number on the lower left corner of the envelope - BID NO. 96-10.



OCONEE MEMORIAL HOSPITAL

August 28, 1996

Norman D. Crain, Supervisor/Chairman
Members of Oconee County Council
208 Booker Drive
Walhalla, SC 29671

Re: Proposed exchange of properties

Dear Mr. Crain and Members of the Council:

The officers and directors of Oconee Memorial Hospital are very concerned regarding the decision by the Council to submit to referendum a proposal which has been pending which involves the Hospital trading property it owns near the Oconee County Landfill for the real property which it leases from the County.

You should be aware that the Hospital does not want to be responsible for the time, expense and effort required to put this proposal to a referendum in light of the fact that this proposal was not instigated by the Hospital nor was it the Hospital's original idea. A review of the history of this arrangement will show that on April 21, 1995, Mr. Norman Crain, on behalf of Oconee County Council, wrote to me asking that the Hospital grant to the County a first right of refusal should the Hospital ever decide to sell its property adjacent to the Oconee County Landfill. That request was considered by the Hospital Board and July 12, 1995, the Hospital Board responded to Mr. Crain's request with a proposal that the entities simply exchange properties, which would be patently beneficial to both organizations.

It is the Hospital's view that the County's position should be to simply either accept or reject that proposal. We certainly do not wish nor do we seek a referendum on the matter inasmuch as the original proposal was merely a response to an inquiry by the County. If the County does not believe the proposal to be beneficial, we believe you should simply decline.

The Hospital Board's view is that this matter has been allowed to escalate to a point that the original intent and positions of the parties are being overlooked. For that reason, by action of the Board of Oconee Memorial Hospital, the proposal made to the County on July 12, 1995 for the exchange of these properties is hereby withdrawn.

Norman D. Crain
Members of Oconee County Council
August 28, 1996

Page 2

Should there be any interest in an exchange of these properties in the future, we would be more than happy to discuss it at that time.

Sincerely,

A handwritten signature in black ink, appearing to read "W. H. Hudson". The signature is fluid and cursive, with a long horizontal stroke at the end.

W. H. Hudson,
President

cc: Members of Council
Hospital Board Members

7-31 1995 7:24PM FROM CAIN AND NORTON COUNSELOR

BALLENGER, FEDDER, CAIN & NORTON, L.L.P.

ATTORNEYS AT LAW

339 BYPASS 123 • POST OFFICE BOX 698 • SENECA, SC 29679

TELEPHONE (803) 882-6608

FACSIMILE (803) 882-7182

W. J. Fedder (Of Counsel)
Timothy M. Cain, P.A.
Bradley A. Norton

William H. Ballenger (Of Counsel)
Karen F. Ballenger

July 31, 1995

Mr. Norman D. Crain
Supervisor - Chairman
Oconee County Council
208 Booker Drive
Walhalla, South Carolina 29691

Mr. Harrison Orr
Oconee County Council
208 Booker Drive
Walhalla, South Carolina 29691

Re: Proposed exchange of property with
Oconee Memorial Hospital, Inc.

Gentlemen:

It is my understanding that a meeting has been scheduled for the special committee of the County Council appointed to consider the above-referenced proposal for August 1, 1995. As I advised last week when the meeting was requested, I will be unable to attend at this date and time due to family medical circumstances.

I am not sure of the purpose of this meeting. However, since I was requested to review the legalities of the proposal of the Corporation which operates the Hospital, I have discussed the proposal with the Corporation's attorney several times and we have agreed to meet to review the same in detail, and to work together to obtain an historical perspective of how and why the property was titled in the County. Additionally, my office is in the process of conducting title examinations of the property owned by Oconee County to determine the status of the title and any restrictions of record.

Again, I am unsure of the purpose of the scheduled meeting. However, it may be that in the event it is determined that there are no legal impediments to such an exchange, the County may want to impose certain restrictions or "safeguards" on any public property conveyed to the Corporation to insure that the same is used for the provision of health care and related services to the populace of the County. There are other issues which the Council may desire to address, to include requiring adequate safeguards to assure that emergency medical services continue to be provided on a county - wide basis and that persons who need medical care will be treated at the hospital regardless of their ability to pay.

Mr. Norman D. Crain
Mr. Harrison Orr
July 31, 1995
page 2

Finally, once the legal implications of such a transaction are determined, if Council desires to move forward with the conveyance, a determination will need to be made as to the respective values of the properties which are the subject of the proposal. This would require that independent appraisals of the properties and improvements thereon be obtained from appraisers qualified to render such opinions.

These are some of the issues which have been identified which must be addressed when considering the proposal of the Corporation which currently operates the hospital. Discussions incident to such a proposal, which involves millions of dollars should, of course, be approached cautiously and with due regard for the fiduciary responsibilities of the County Council to the people of the county.

I will keep you advised of our efforts. In the interim, should there be any questions, or if any member of Council desires to discuss this matter, please do not hesitate to call upon me.

Thanking you for your attention to this matter, I remain,

Sincerely,



Timothy M. Cain
County Attorney

cc: Council Members

OMH OCONEE MEMORIAL HOSPITAL

July 12, 1995

Mr. Norman D. Crain, Supervisor/Chairman
Oconee County Council Members
208 Booker Drive
Walhalla, SC 29691

Dear Mr. Crain and Council Members:

I am writing in response to your letter of April 21, 1995 requesting that Oconee County be given the first right of refusal should the Hospital decide to sell its property adjacent to the Oconee County Landfill. Oconee Memorial Hospital has acquired the interest of the DAR School in this property and is now sole owner.

The Board of Directors of the Hospital have considered your request carefully. Accompanying this letter, you will find a Proposal of the Board which would result in Oconee County acquiring ownership of those lands in exchange for properties the County already owns. The Board recognizes that it and the council are both obligated to the community of Oconee County and with the best interests of the community in mind, considers this proposal to be very beneficial to both the County and the Hospital.

We hope you will look upon this proposal favorably.

Yours very truly,



W. H. Hudson, President

sh

Enclosure

PROPOSAL

TO: Oconee County, South Carolina

FROM: Board of Directors
Oconee Memorial Hospital, Inc.

RE: Exchange of Properties

DATE: July 12, 1995

Oconee Memorial Hospital, Inc. (hereinafter "Hospital") herewith tenders a proposal to trade certain real property owned by the Hospital to Oconee County (hereinafter "County"), together with other considerations, in exchange for receiving from the County the real property which the County owns currently leased by the County to the Hospital.

The Hospital believes that the consummation of the transaction proposed here is supported by certain facts which should be kept in mind by way of explanation of the basis of the Hospital's proposal. to wit:

1. On July 9, 1959, the Hospital conveyed to the County two (2) tracts of the Hospital's land, one containing thirty-three and eight-tenths (33.8) acres, more or less, and a second containing nineteen and ninety-two one-hundredths (19.92) acres, more or less, upon which is located the Hospital's physical plant and facility operating under the name and style of Oconee Memorial Hospital. In that transaction, the Board of Directors of the Hospital authorized the granting of a pledge to the County of so much of the Doyle Fund as would be required to match funds available to the County under the Hill-Burton Act, not to exceed a total of ninety thousand (\$90,000) dollars. All of this was done at no cost to the County and in support of Act #483 of the Legislature of the State of South Carolina declaring that *"the General Assembly finds that there is a need for public hospital facilities in Oconee County which requires an expenditure by Oconee County of nine hundred thousand (\$900,000) dollars, and such funds, with federal aid made available through the so-called Hill-Burton Act, will be sufficient to enable such facility to be provided."*

2. Pursuant to Legislative Act #483, the Hospital and the County, by their duly authorized officers, negotiated the terms and conditions and entered into an agreement dated June 29, 1959 entitled *"Indenture of Lease"*, which was then executed on behalf of the County and the Hospital. The Lease was subsequently renewed on the 29th day of June, 1974 and again in 1989, and was ultimately replaced by a thirty (30)

year Lease for the same properties executed as part of the seventeen and one-half million (\$17,500,000) dollars Hospital Revenue Bond Series 1995, dated March 22, 1995, which Lease is presently in full force and effect.

3. It is the sole purpose and objective of the Hospital to further serve the health and retirement needs of the citizens of the County which would be aided and assisted by the Hospital's reacquiring the property which is the subject of the Lease, thereby enabling the Hospital to expeditiously and efficiently follow land use studies recommended to it and better serve the community by having control of its own resources.

4. The Hospital owns fifty-seven and seven-three one-hundredths (57.73) acres, more or less, of real property which lies adjacent to the County-owned landfill, and the County is in need of the Hospital's property to be used for the continued maintenance of the landfill so that the County's acquisition of the Hospital's lands would be of great benefit to the County.

PROPOSAL

For and in consideration of the foregoing and the mutual benefits flowing to each party, the Hospital proposes to trade its fifty-seven and seven-three one-hundredths (57.73) acres, more or less, which the Hospital owns adjacent to the County's landfill to the County, together with the following additional considerations:

- i. withdraw its annual request of one hundred twenty-five thousand (\$125,000) dollars to support its EMS system;
- ii. be solely responsible for and pay the final two (2) payments due from the County on June 30, 1996 and June 30, 1997 on the 1977 Hospital Bond, in the amount of two hundred thirty-six thousand five hundred seventy-nine (\$236,579) dollars each;

IN EXCHANGE FOR the conveyance by the County to the Hospital of the two (2) tracts of the land containing thirty-three and eight-tenths (33.8) acres, more or less, and containing nineteen and ninety-two one-hundredths (19.92) acres, more or less, conveyed to the County by the Hospital upon which is located the Hospital's physical plant and facility.

CONCLUSION

By trading properties as outlined herein, the County acquires property which it needs for the maintenance and continuation of the County landfill facility, as well as benefiting financially from the payments to be made by the Hospital as well as the

annual contributions to its EMS system which the Hospital is willing to forego over the thirty (30) year term of the Lease, amounting to in excess of four million three hundred thousand (\$4,300,000) dollars. On the other hand, the County is only giving up lands which it was paid to take to begin with, as part of a federal financing arrangement.

The Hospital views this as a very attractive proposal for the County while putting itself in a position to better follow a master plan well into the future of the County to insure quality health care and retirement facilities for the citizens of the County.

Respectfully submitted,

OCONEE MEMORIAL HOSPITAL, INC.

By: *A. L. Berman*
Chairman, Board of Directors

And: *W. H. Hudson* / sh
President

Oconee County Council

Mary Frances Burrell
District One
Post Office Box 53
Tamassee, SC 29686

Harrison E. Orr
District Two
Post Office Box 1068
Walhalla, SC 29691

Harry R. Hamilton
District Three
702 Quincy Road
Seneca, SC 29678

Public Service Building
208 Booker Drive
Walhalla, SC 29691
(803) 638-4244

Norman D. Crain
Supervisor, Chairman
208 Booker Drive
Walhalla, SC 29691
(803) 638-4242

Roy B. Strickland
District Four
203 Isundega Street
Westminster, SC 29693

Alton K. Williams
District Five
901 Pine Grove Road
Seneca, SC 29678

Timothy M. Cain
County Attorney
Post Office Box 698
Seneca, SC 29679

April 21, 1995

Mr. W. H. Hudson, President
Oconee Memorial Hospital
P. O. Box 858
Seneca, SC 29679

Dear Ham:

As you are aware Oconee County operates a landfill on property which corners at Wells Highway (SC-37-488) and North Strawberry Farm Road (SC-37-87). This landfill is scheduled to be closed with a few months.

Certain closure assessment procedures have already been conducted. Preliminary results from test borings on the landfill site indicate the potential exists for impact upon adjacent ground water. At this time the extent of any such impact is unknown.

Records at the Oconee County Courthouse indicate that Tamassee DAR School (DAR) and Oconee Memorial Hospital (OMH) co-own 57.73 acres (the property) adjacent to the landfill (see attached plat).

The purpose of this correspondence is to respectfully request that Oconee County be given "first right of refusal" if OMH and DAR are interested in selling the property.

Your early attention and response to this request will be greatly appreciated.

As always, If I can be of further assistance in this matter please do not hesitate to contact me.

With warm regards, I am

Respectfully,

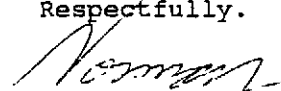
Norman D. Crain
Supervisor-Chairman
Oconee County Council

NDC/og

C: Mr. Harrison E. Orr

LINE	BEARING	DISTANCE
L1	N 57° 16' 13" W	296.85
L2	N 97° 15' 30" W	108.04
L3	N 97° 30' 23" W	50.00
L4	N 50° 35' 17" W	120.01
L5	N 54° 00' 00" E	85.33
L6	N 50° 40' 42" W	70.75
L7	N 50° 30' 00" E	250.00
L8	N 50° 40' 42" W	36.68
L9	S 52° 27' 25" W	42.21
L10	N 60° 40' 30" W	30.84
L11	N 5° 27' 47" E	36.40
L12	N 23° 31' 19" W	140.00
L13	N 23° 30' 42" W	247.50
L14	N 23° 40' 42" W	144.50
L15	N 41° 11' 14" W	310.53
L16	N 81° 00' 27" E	151.80
L17	S 20° 52' 08" E	100.00
L18	S 47° 34' 24" E	47.81
L19	S 43° 18' 12" W	50.41
L20	N 51° 14' 30" E	303.83
L21	N 51° 00' 04" E	175.36
L22	N 51° 00' 25" E	167.60
L23	N 51° 07' 54" E	100.64
L24	N 25° 21' 25" E	100.20
L25	N 19° 27' 10" E	184.26
L26	N 13° 37' 48" E	162.70
L27	N 0° 33' 04" E	120.89
L28	N 4° 45' 18" E	136.89

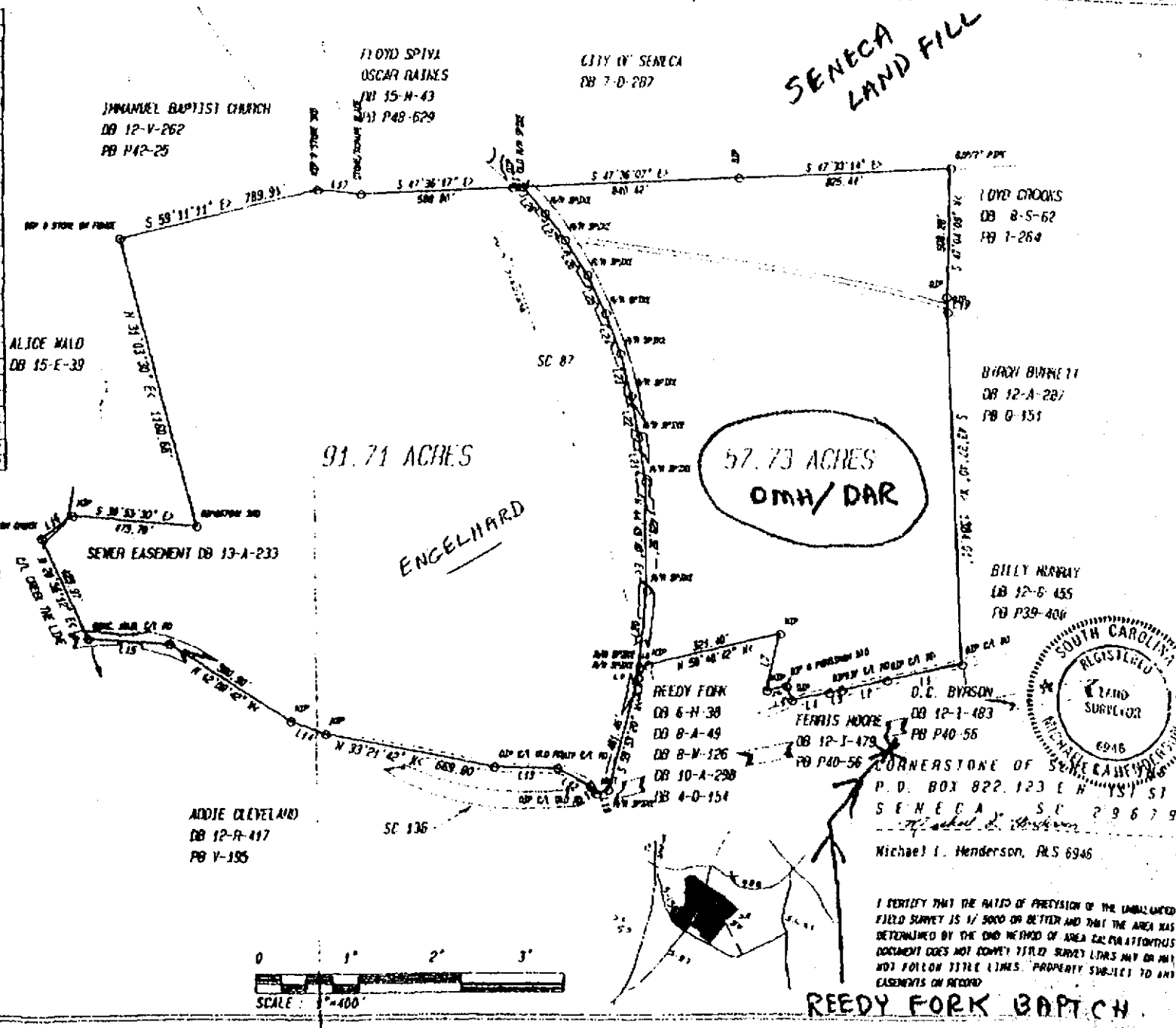

ION : PROPERTY OF TAMASSEE O.A.R. SCHOOL AND
 MORIAL HOSPITAL
 : STATE OF SOUTH CAROLINA, COUNTY OF DOBEE,
 WNSHIP
 ARCEL : 149.44 ACRES
 BRUARY 22, 1985

PREPARED FOR :
 E D.A.R. SCHOOL
 MEMORIAL HOSPITAL

BOOK 5-11-383
 2-20-82-008

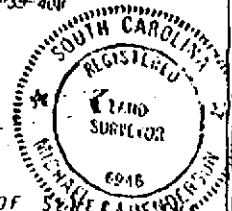

CORNERSTONE OF SENECA MEMORIAL HOSPITAL
 P.O. BOX 822, 123 E. H. YS1 ST
 SENECA, S.C. 29679
 Michael I. Henderson, PLS 6946

I CERTIFY THAT THE RATIO OF PRECISION OF THE UNBALANCED FIELD SURVEY IS 1/3000 OR BETTER AND THAT THE AREA HAS DETERMINED BY THE OLD METHOD OF AREA CALCULATION THIS DOCUMENT DOES NOT COMPLY WITH SURVEY LINES MAY OR MAY NOT FOLLOW TITLE LINES. PROPERTY SUBJECT TO ALL EASEMENTS ON RECORD

REEDY FORK BAPT CH



CONTRACT OF SALE



THIS CONTRACT OF SALE ENTERED INTO THIS 24th DAY OF April, 1995, by and between Oconee Memorial Hospital and D.A.R. School hereinafter collectively called "SELLER", and Oconee County hereinafter collectively called "PURCHASER", WITNESSETH:

SELLER agrees to sell and PURCHASER agrees to purchase the following described real property:

57.73 acres on Strawberry Farm Road, Seneca South Carolina known in the County Courthouse records as tax map # 268-00-03-096

for the sum of two thousand per acre (\$2000/acre) Dollars. SELLER acknowledges receipt of () Dollars in (CASH) (CHECK) from PURCHASER as a binder and earnest money,

to be held in escrow by () in its escrow or trust account. The listing Landwith Appraisal and selling Mt. West Realty brokers do not guarantee payment of any check(s) accepted as earnest money or the marketability of title to the subject premises, nor its condition or state of repair. The balance of the purchase price is to be paid in cash or FINANCING ADDENDUM ATTACHED.

COVENANTS AND PROMISES OF SELLER: (1) To convey fee simple title to the subject premises by way of a general warranty deed free of encumbrances, liens or assessment at the time of closing, subject only to existing easements, rights of way, restrictions or zoning ordinances which do not render the title unmarketable: (2) To deliver the property at the time of closing in essentially the same condition as to state of repair as of the date hereof.

COVENANTS AND PROMISES OF PURCHASER: (1) To pay the balance of the purchase price at the date of closing; (2) Purchaser has made a COMPLETE AND ACCEPTABLE INSPECTION of the real property or INSPECTION ADDENDUM ATTACHED. Unless noted herein or agreed to by SELLER in writing, PURCHASER shall accept such premises free and clear of any warranties, expressed or implied, respecting the condition, merchantability or usefulness of the premises or any improvement thereon. It is the PURCHASER'S obligation to secure and inspect a copy of applicable protective covenants and restrictions.

ADJUSTMENTS: Taxes, water, sewer charges, fuel oil, electricity, rents as when collected, and other assessments, including homeowners association fees, shall be prorated as of the date of closing.

FIRE OR CASUALTY: In case the property herein referred to is destroyed wholly or partially by fire or other casualty prior to delivery of deed, PURCHASER or SELLER shall have the option for ten (10) days thereafter of proceeding hereunder, or of terminating this agreement.

DEFAULT: If the PURCHASER shall default under this agreement, the SELLER shall have the option of pursuing all legal and equitable remedies available including, but not limited to reasonable attorney's fees and/or rescinding this contract. In the event the contract is rescinded, one-half of the earnest money shall then be paid to the Broker(s), not to exceed the commission due such Broker, and the remaining balance of earnest money shall be paid to the SELLER. Upon default by the SELLER, the PURCHASER shall have the option of suing for damages or specific performance, and/or rescinding this contract. Upon default by the SELLER, if the PURCHASER elects to rescind this agreement, he will be refunded all sums paid hereunder and in addition shall be reimbursed by the SELLER for actual costs incurred including, but not limited to, credit report, appraisal fee, survey, cost of title examination.

WOOD INFESTATION: NA to provide official South Carolina Wood Infestation Report (CL-100) from a licensed and bonded company. SELLER agrees to make repairs required by licensed and bonded company or rescind the contract.

FIXTURES AND PERSONAL PROPERTY: This sale includes all improvements, fixtures, appurtenances and in addition the following items of personal property Sellers to be allowed to remove remaining timber within one year from date of closing.

FACSIMILE: Contract documents supplied by facsimile will be considered binding on all parties until and unless original documents are received by the party seeking to enforce the Contract.

JOINT COVENANTS AND PROMISES OF SELLER AND PURCHASER: (1) SELLER shall tender necessary documents to transfer title, and PURCHASER shall tender the balance of the purchase price in order to CLOSE THIS TRANSACTION ON OR BEFORE June 30 1995; (2) purchaser to be given POSSESSION of the property at closing.

(3) This contract and agreement is subject to the following terms and conditions, to-wit: (blank lines)

(4) This contract, and any addendums that have been signed by all parties and made a part of this agreement, constitutes the entire agreement of the parties and can only be changed by written agreement of the parties.

SELLERS CLOSING COSTS sub preparation, County Seal stamps, real estate commission, pro-rata taxes.

PURCHASERS CLOSING COSTS: Any expenses associated with County procurement requirements

WITNESS: PURCHASER: SS# DATE
WITNESS: PURCHASER: SS# DATE
WITNESS: SELLER: SS# DATE
WITNESS: SELLER: SS# DATE

INFORMATION & DISCLOSURE REGARDING
REAL ESTATE AGENCY RELATIONSHIPS

An agency relationship arises whenever two persons agree that one is to act on behalf of the other and in accordance with the other's directions. The creation of an agency relationship imposes certain legal duties on the agent. They are the fiduciary duties of loyalty, obedience, disclosure, confidentiality, reasonable care and diligence, and accounting in dealings with the client.

Before a seller or a buyer enters into a discussion with a real estate agent regarding a real property transaction, the seller and the buyer should each understand what type of agency relationship or representation the seller and/or the buyer may have with each agent in that transaction.

IF THE AGENT REPRESENTS THE SELLER: The agent becomes the seller's agent by entering into a listing agreement with the seller or by agreeing to act as a subagent through a listing agent. A subagent may work for a different real estate company. A listing agent or subagent can assist the buyer but does not represent the buyer. A listing agent or subagent must place the interests of the seller first. The buyer should not tell a listing agent or subagent anything the buyer would not want the seller to know, because a listing agent or subagent must disclose to the seller any information he or she knows. It is an agent's duty to disclose to all parties all facts known to the agent which materially affect the value or desirability of the property, and which are not known to or apparent with diligent attention and observation of the parties.

IF THE AGENT REPRESENTS THE BUYER: The agent typically becomes the buyer's agent by entering into an agreement to represent the buyer. A buyer's agent can assist the seller but does not represent the seller. A buyer's agent must place the interests of the buyer first. The seller should not tell a buyer's agent anything of a personal or confidential nature that the seller would not want the buyer to know, because a buyer's agent must disclose to the buyer any information he or she knows. It is an agent's duty to disclose to all parties all facts known to the agent which materially affect the value or desirability of the property, and which are not known to or apparent with diligent attention and observation of the parties.

IF THE AGENT REPRESENTS BOTH THE SELLER AND THE BUYER AT THE SAME TIME: An agent may not act as an agent for more than one party to a transaction without the disclosed and informed consent of both the seller and the buyer. The agent is required to treat both the seller and the buyer honestly and impartially so as not to favor one party or work to the disadvantage of any party. Unless written permission from the seller or the buyer, whichever is appropriate, is obtained, the agent is prohibited from disclosing: (a) that the seller will accept a price less than the asking price; (b) that the buyer will pay a price greater than the price submitted in a written offer; (c) any confidential information; or (d) any other information a party specifically instructs the agent in writing not to disclose, unless disclosure is required by law. Therefore, the agent's duties are more limited if he or she represents both parties. There are potential conflicts of interest when an agent represents more than one party. The agent is obligated to inform each party of all facts the agent knows which would affect the party's decision to permit the agent to represent both the seller and the buyer.

You have the right to choose the type of representation you wish to receive. Payment of a fee to an agent does not necessarily establish that the agent represents you. If you have any questions regarding the duties and responsibilities of the agent, you should resolve these questions before going further. Regardless of the agency relationships which may be established, you have the responsibility to protect your own interests. Once you have read and discussed this information with the agent, please acknowledge your receipt of a copy of this form. Your cooperation will help the agent to comply with the Regulations of the South Carolina Department of Labor, Licensing and Regulation, Real Estate Commission. The agent is required to provide this form to you and to disclose below whom the agent represents.

The above duties of the agent in a real estate transaction do not relieve a seller or a buyer from the responsibility to protect his/her own interests. You should carefully read all agreements to assure that they adequately express your understanding of the transaction. If legal or tax advice is desired, consult a competent professional.

Throughout your real property transaction you may receive more than one disclosure form, depending upon the number of agents assisting in the transaction. The law requires each agent with whom you have more than a casual relationship to present you with this disclosure form. You should read its contents each time it is presented to you, considering the relationship between you and the real estate agent in your specific transaction.

DISCLOSURE OF AGENCY:
Agent named below represents: seller buyer seller and buyer
Mt. Rest Realty By: Tommy [Signature] Date: 4/24/95
Brokerage Company Name (Agent) Broker or Sales Associate

ACKNOWLEDGMENT OF RECEIPT OF AGENCY DISCLOSURE FORM: I acknowledge I have received a copy of this form. I understand that agreements I may sign may affect or change the agency relationships and that the agent may represent both seller and buyer only with the full knowledge and written consent of all parties.

Date: _____
Seller or Buyer

Date: _____
Seller or Buyer

This form is promulgated by the South Carolina Department of Labor, Licensing and Regulation, Real Estate Commission, for mandatory use by real estate licensees. Agents must conduct transactions without regard to race, color, sex, religion, handicap, familial status, or national origin.

OCONEE COUNTY COUNCIL

PROCLAMATION 96-1

WHEREAS, INDUSTRY in OCONEE COUNTY is vital to the Community's and State's economic health; and

WHEREAS, OCONEE COUNTY'S existing INDUSTRIES are producing the highest quality products sold throughout the state, nation and world; and

WHEREAS, the people of Oconee County manufacture these products; and

WHEREAS, OCONEE COUNTY INDUSTRIES are leaders in continuing economic development for the COUNTY and help sustain our quality of life; and

NOW, THEREFORE, WE, OCONEE COUNTY COUNCIL do hereby this Seventeenth day of September, 1996 proclaim the week of September 16-20, 1996 as "**INDUSTRY APPRECIATION WEEK**" and urge all residents to salute our INDUSTRIES and their EMPLOYEES for their many contributions to our community.

ADOPTED & APPROVED on first and final reading by Oconee County Council, in session duly assembled, this 17th day of September, 1996.

Norman D. Crain
Supervisor-Chairman
Oconee County Council

Attest:

Opal O. Green
Council Clerk

September 10, 1996

Mr. Norman D. Crain
Oconee County
208 Booker Blvd.
Walhalla, SC 29691

RE: Clemson-Oconee County Airport
New Terminal Building
TBI No. 3401-9602

Dear Mr. Crain:

This morning, Marion Lyles, Airport Manager, contacted me requesting that I prepare a letter for you outlining the steps that can be undertaken in the near future that will help short cut the terminal building design and construction process without wasting any effort.

I have reviewed the project status and believe that there are several tasks that can be undertaken now that will save approximately 30 days on scheduling without having any impact on our budget (i.e., wasted effort). An architect, satisfactory to all parties, can be selected now. Preliminary discussions concerning design parameters, schedule, and other important issues could begin. In addition, the architect could review the terminal building analysis prepared by Talbert & Bright, Inc., and resolve any questions, with input from the County, Dirk Ries, the State, and us. However, I would not encourage any final negotiations with the architect until a final project budget is established. This would provide all parties with a good understanding of the County's preliminary expectations.

Once a budget is established, more specific direction can be provided to the entire design team and final contracts negotiated. Again, I feel that this approach could save at least 30 days and would have no negative impacts on the overall project budget. Please consider the above and discuss with Marion Lyles and Mike Willimon. If we decide to proceed, I will be happy to coordinate any meetings. I look forward to hearing from you.

Yours truly,

J.T. Talbert, III /arr

J.T. Talbert, III, P.E.

JTT/arr

c: Mr. Marion Lyles
Mr. Mike Willimon
Mr. Paul Werts

SEPTEMBER 11, 1996

OCONEE COUNTY COUNCIL
OCONEE COUNTY
WALHALLA, S.C.

COUNCIL MEMBERS:

DUE TO BACK PROBLEMS FOR THE LAST THREE WEEKS AND A TRIP OUT OF TOWN THE FOLLOWING IS SUBMITTED FOR YOUR CONSIDERATION.

YOU APPROVED \$2000 FOR THE 1995-1996 SCHOOL YEAR, TO PROVIDE MATERIALS FOR THE 911 PROGRAM I AGREED TO TEACH THE 3RD GRADES. I COMPLETED THE NINE SCHOOLS AND ALSO PROVIDE INSTRUCTIONS TO THREE PRE-SCHOOL GROUPS. I ALSO PROVIDED THIS 911 INSTRUCTION TO THE SPECIAL EDUCATION GROUPS AT TAMASEE ELEMENTARY SCHOOL, AND PROVIDED THIS 911 INSTRUCTIONS TO 90 SENIOR CITIZENS, AT THE SENECA BAPTIST CHURCH, SENECA, S.C.

I AM REQUESTING \$2500 FOR THE PROGRAM THIS YEAR:

1. 911 CALL SIMULATOR, (C911-PROKIT)	\$ 795
2. 1000 KEY CHAINS, (KT-25) PAGE -5, PURCHASED FROM HINES PRODUCTS.	360
3. 1000 FUN STICKERS, (FS-26) PAGE-8 HINES PRODUCTS	190
4. 1000 SAFE PLAY COLOR & ACTIVITY BOOKS, (SP-88) PG. 10 HINES PRODUCTS.	305
5. 2000 LITER BAGS, (LB-96) PAGE 31 HINES PRODUCTS	305
6. 1000 TELEPHONE MAGNETS, (MP-48) PAGE 2 HINES PRODUCTS.	<u>520</u>
TOTAL:	\$2475

ALL PRODUCTS WILL BE IMPRINTED OCONEE COUNTY 911 PROGRAM IF APPROVED, AND PURCHASED FROM HINES PRODUCTS.

THE '911 CALL SIMULATOR' WAS DEVELOPED BY THE TEXAS TELEPHONE PIONEERS AND THE INFORMATION IS ATTACHED. IF APPROVED I WILL AGREE TO TEACH AN ADDITIONAL TWO YEARS AT NO COST TO THE COUNTY, MY CAP PROGRAM FROM SOUTHERN BELL. EXPIRES SEPTEMBER 1997.

SUBMITTED: ROBERT H. (BOB) LITTLE
911-INSTRUCTOR
13043 MOHAWK PATH
SENECA, S.C. 29678

COPY: BUDDY HAWKS
911-OFFICE

1-866-370-2814

911

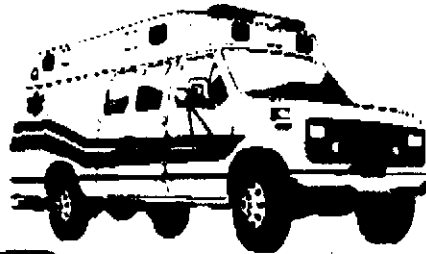

Call Simulator

"Helping People...Help Themselves"

C
COLCOM
INCORPORATED

15827 RANCH ROAD 620 N • AUSTIN, TX 78717 • (800) 888-1978

911 Call Simulator

"Helping People... Help Themselves"



"The 911 Call Simulator is probably one of the best technological advances we've seen in public safety education in a long time."

Fire Marshall Keith Tanner
Round Rock Fire Dept.

911 CALL SIMULATOR FACT SHEET

WHAT IS THE 911 CALL SIMULATOR?

The 911 Call Simulator is an *interactive training device* specifically designed to give young children and older adults the opportunity to experience a 911 call and learn how and when its use is appropriate.

Functioning much like our public 911 system, the 911 Call Simulator provides students with dial tone, ringing, busy signal, and a "call back" feature. Once the student selects 9-1-1, a link is automatically established between the student and the instructor. At that time, the instructor, acting as the 911 operator, can prompt the student to answer various questions with regard to particular emergency situations, such as a fire or a burglary. When the call has been successfully completed, the instructor can then reward the student by activating an authentic-sounding, prerecorded emergency vehicle sound to indicate "help is on its way." Students benefit greatly from this role playing experience, learning what to expect from an actual 911 operator and gaining a newfound confidence in handling emergency situations.

Three different models are available to meet your particular training needs. All three models come equipped with two telephones, a call box, and a lightweight, durable carrying case (with built-in speaker). This protective case significantly reduces wear to the unit and makes transportation between demonstration sites easy and efficient. Our Professional and Executives models provide the added benefits of an Emergency Sound Package and either a portable headset telephone or a wireless headset telephone - great for the instructor who wants to be free to use his or her hands and have maximum mobility.

WHAT BENEFITS DOES THE 911 CALL SIMULATOR PROVIDE?

- Empowers children & adults by providing them with the invaluable skill of effectively handling emergency situations.
- "Hands-on" experience promotes active involvement in the lesson and greater retention of the acquired knowledge and skills.
- Loud speaker allows every emergency situation presented in training to be broadcast and shared among group members.
- Assembly is simple & quick with labeled ports and easy-to-understand instructions provided with every unit.
- Each unit is packaged in a *lightweight, durable carrying case*. (Great for transporting between demonstration sites).
- Three different models are available to meet various budget and demonstration requirements.
- Multiple applications: grade school education, education for the elderly, community demonstrations, safety programs, public relations events, trade shows, library & museum exhibits.
- Colcom provides in-house repair and a *toll free helpline* to assist with questions.

HOW CAN MY ORGANIZATION ACQUIRE A 911 CALL SIMULATOR?

1. Fill out the enclosed Order Form:
2. Mail the completed form to our address: 15527 RR 620 N. Austin, TX 78717; OR simply
3. Fax Us (512) 244-6694. AND
4. DON'T FORGET TO VISIT OUR WEB PAGE @ <http://www.eden.com/~colcom>

HOW DOES EACH MODEL DIFFER?

PIONEER (BASIC) MODEL C911 TELKIT

- Simulator Module
- AC/DC Transformer
- Carrying Case w/Built-In Speaker
- Two Telephones

The Pioneer model has all the essential components required for basic 911 training, and is priced to meet even the most conservative of budgets.

PROFESSIONAL MODEL C911 PROKIT

- Simulator Module
- AC/DC Transformer
- Carrying Case w/Built-In Speaker
- Two Telephones
- Portable Headset/Telephone
- Emergency Sound Package

The Professional model provides the added benefits of an Emergency Sound Package (ESP) and portable headset telephone. With the ESP, instructors can reward their students by activating one of four available emergency vehicle sounds. With just one touch of a button, students can experience the prerecorded voice of a 911 dispatcher, the fast or slow siren of a police car, or even the horn of a fire truck. And with the portable headset telephone, instructors are free to use their hands to assist students during demonstrations.

EXECUTIVE MODEL C911 EXECKIT

- Simulator Module
- AC/DC Transformer
- Carrying Case w/Built-In Speaker
- Two Telephones
- Wireless Headset/Telephone
- Emergency Sound Package

The "wireless" capability of the Executive model allows the instructor to create the most realistic training situations. Free from cords, the instructor can take a position away from the student's view, allowing the student to experience the reality of making a 911 call without an adult's guidance.

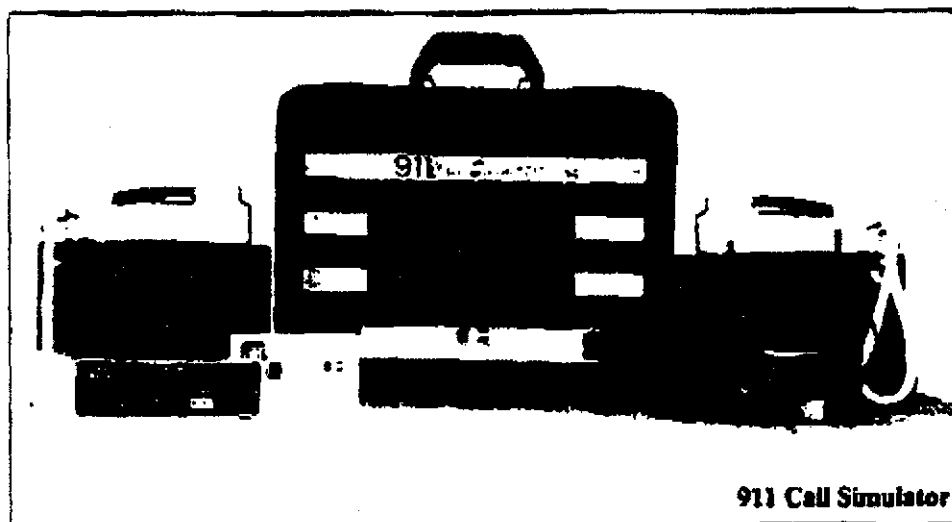

911 Call Simulator



SOUTH CAROLINA
DEPARTMENT OF COMMERCE

David M. Beasley
Governor

September 13, 1996

Robert V. Royall, Jr.
Secretary

Mr. Norman D. Crain
County Supervisor
Oconee County
208 Booker Drive
Walhalla, SC 29691

Dear Mr. Crain:

Thank you for your consideration regarding Oconee County accepting the Grant Award from the Coordinating Council for Economic Development for the road work for Compact Air Products, Inc. I am writing to address the concerns you have expressed.

Since the road involved is a Federal Highway (US Highway 123/76) and is maintained by the South Carolina Department of Transportation, Oconee County will not be responsible for its maintenance now nor after the turn lanes are constructed. Maintenance would continue to be the responsibility of the Department of Transportation.

The Coordinating Council for Economic Development has never and would never require nor request the closure of a road during or after construction using one of our grants. Specifically, we would not close Seed Farm Road, at any time.

As I understand, the other concern is cost overruns. Since quotes have been obtained in the amount of \$40,500.00, the grant will correspond with the cost. In the event, a new quote is needed and exceeds this, the amount of the grant will increase as long as the new price is for the exact same work. In this case, I see no circumstances where there would be any overruns.

If you have additional questions or concerns, please let me know. We look forward to working with you on this project.

Sincerely,

A handwritten signature in dark ink, appearing to read "H.M. Alexander".

H.M. Alexander
Director
Coordinating Council for Economic Development

hma/ro